

SHARP

DX-2500N
Digital Full Colour Multifunctional System

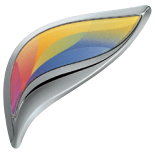

NETWORK-READY A3 COLOUR MFP WITH
EXPANDABLE DESIGN

Your business is evolving /**This is Why** you need a colour
MFP that's fit for the future.

Great teamwork brings superior performance /This is Why we made this versatile cloud-capable MFP.

If you're looking for an affordable A3 network colour MFP which has all the capabilities you need today - and can be easily upgraded to meet the challenges of the future - you need to take a close look at the cloud-capable DX-2500N, with optional wireless network connectivity.

As well as enjoying fast, high quality printing, you'll find that copying and scanning (on both sides of the page) is both quick and easy. The integrated document feeder can automatically process an entire stack of 100 sheets while you get on with something else.

Your team will also appreciate the other extra value features we've included as standard.

Two USB ports are provided for walk-up printing and scanning. There's a suite of advanced copying functions including Card Shot and Electronic Sorting. And you can even scan documents directly to your PC.

What's more, a large colour touch screen, with quick links to popular features, makes all of this intuitive and easy to control. There's no need to study a manual: just walk up and start using it.

Connect to your colleagues in the cloud

The DX-2500N is cloud-capable and fully compatible with Sharp Cloud Portal Office*¹ - an enterprise-wide information sharing environment which improves teamwork by linking printers, MFPs, tablets, phones, PCs and BIG PAD interactive whiteboards.

PERFECT FOR GROWING BUSINESSES AND DEMANDING WORKGROUPS



INTUITIVE, FULL COLOUR LCD CONTROL PANEL

*¹ Requires optional Sharp OSA and Cloud Portal Office subscription.

It's a mobile world /This is Why we make it easy to connect your phones and tablets.

The power and versatility of the DX-2500N makes it ideal for everyone in your office. And not just employees, but visitors, too.

Sharpdesk Mobile*² lets everyone use the printing and scanning features of your MFP directly from their tablets and mobile phones. There's no tricky technology to master and no cable connections. It's as easy as printing from a PC.

But why stop there? In addition to Sharpdesk Mobile, you can specify any of these options as part of the package, or simply add them in the future as your needs change.

Inner finisher – this space-saving finisher takes care of your sorting, stapling and hole punching needs, creating neatly finished documents, collated and ready for collection.

Extra paper drawers – expand the paper supply from 600 sheets right the way up to 3,100 sheets for longer uninterrupted printing.

250GB hard drive – a large internal hard drive which can be used to store documents and images, and can be accessed across the network.

Sharpdesk – use this powerful software to manage and organise files on your PC, including documents that you have scanned on the MFP.

PostScript 3 emulation – choose this if you'll be printing lots of documents that contain graphics.



EFFICIENCY ENHANCING PRINT, COPY, SCAN AND FINISHING CAPABILITIES

Keeping information safe and secure

The DX-2500N protects against unauthorised access, and has a whole range of standard and optional security safeguards normally found in much more expensive machines*³.

Energy efficiency

All Sharp MFPs are Energy Star certified and designed to meet your environmental objectives by using less energy.

*² Availability varies by country/region.

*³ Optional Productivity Kit (MX-EB17) adds data encryption and auto deletion.

Specifications

General

Engine speed *1 (ppm/cpm) (Max)	A4 25	A3 11
Paper size *2 (Min – Max)	A5R – A3W	
Paper weight (g/m ²)	60 – 220	
Drawers	55 – 300	
Paper capacity (Std – Max)	600 – 3,100	
Sheets *3	1 – 4 (plus bypass tray)	
Drawers		

Copier

Original paper size (Max)	A3	
First copy time *7 (seconds)	Full colour	B/W
	10.0	7.4
Continuous copies (Max)	999	
Print resolution (dpi)	600 x 600	
Scan (colour)	600 x 600; 600 x 400; 600 x 300	
Scan (B/W)	600 x 600; 9,600 (equivalent) x 600 (depending on copy mode)	
Print		
Gradation levels	256	
Zoom range (%)	25 – 400 (25 – 200 using RSPF) in 1% increments	
Preset copy ratios	10 (5R/5E)	

Network Scanner

Scan method	Push scan (via control panel) Pull scan (TWAIN-compliant application) *5	
Resolution (dpi) (Max)	100, 200, 300, 400, 600	
Push scan	75, 100, 150, 200, 300, 400, 600;	
Pull scan *5	50 – 9,600 via user setting *8	
File formats	TIFF, PDF, PDF/A, encrypted PDF, JPEG *9, XPS	
Scan destinations	e-mail, desktop, FTP server, network folder (SMB), USB memory	
Scanner utilities	Sharpdesk, Sharpdesk Mobile	

Document Filing (optional MX-EB17 required)

Document filing capacity *10	Pages	Files
Main & custom folders	20,000	3,000
Quick file folder	10,000	1,000
Stored jobs *11	Copy, print, scan, fax transmission	
Storage folders	Quick file folder, main folder, custom folder (max. 1,000)	
Confidential storage	Password protection (for main & custom folders)	

Warm-up time *4 (seconds)	45	
Memory (GB)	2	
Copier/Printer (shared)	1 *5	
Option	250 *5 *6	
HDD		
Power requirements	Rated local AC voltage ±10%, 50/60 Hz	
Power consumption (kW) (Max)	1.84 (220 to 240V)	
Dimensions (mm) (W x D x H)	583 x 617 x 834	
Weight (kg)	73	

Network Printer

Resolution (dpi)	600 x 600; 9,600 (equivalent) x 600	
Interface	USB 2.0, 10Base-T/100Base-TX/1000Base-T	
Supported OS	Std	Windows Server® 2008, Windows Server® 2008 R2, Windows Server® 2012, Windows Server® 2012 R2, Windows Vista®, Windows® 7, Windows® 8, Windows® 8.1, Mac OS X 10.4, 10.5, 10.6, 10.7, 10.8, 10.9, 10.10
	Opt *12	
Network protocols	TCP/IP (IPv4, IPv6), IPX/SPX (NetWare), EtherTalk *12 (AppleTalk)	
Printing protocols *13	LPR, Raw TCP (port 9100), POP3 (e-mail printing), HTTP, Novell Printserver application with NDS and Bindery, FTP for downloading print files, EtherTalk printing, IPP	
PDL	Std	Sharp Advanced Printing Language-c, PCL 6 emulation *14
	Opt	PostScript® 3™ emulation *12
Available fonts	80 fonts for PCL, 136 fonts for PostScript® 3™ emulation	

Fax (optional MX-FX11 required)

Compression method	MH/MR/MMR/JBIG	
Communication protocol	Super G3/G3	
Transmission time *15 (seconds)	Less than 3	
Modem speed (bps)	33,600 – 2,400 with automatic fallback	
Transmission resolution (dpi)	Std	203.2 x 97.8
	Ultra Fine	406.4 x 391
Recording width	A5 – A3	
Memory (GB) (Std – Max)	0.5 – 1 *5	
Greyscale levels	256	

External Dimensions

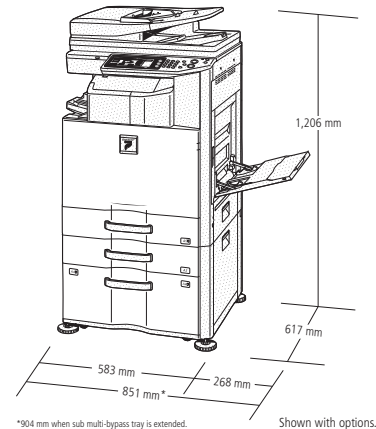

This is Why

www.sharp.eu

SHARP

Notes

*1 Long-edge feeding. *2 Only short-edge feeding can be used with A5 paper. *3 80 g/m². *4 At rated voltage, 23°C (73.4°F). May vary depending on operating conditions and environment. *5 Requires optional MX-EB17. *6 HDD capacity depends on procurement and sourcing status. *7 Long-edge feeding of A4 sheets from 1st paper tray, using document glass, without Auto Colour Selection and Auto Colour mode. MFP in fully ready condition. May vary depending on operating conditions and environment. *8 Resolutions higher than 600 dpi are interpolated. *9 Colour only. *10 Storage capacity will vary depending on the type of document and the scan settings. *11 Some features require option(s). *12 Requires optional MX-PK11. *13 IPv6 is supported only by LPR printing protocol. *14 As print performance may decline with some types of data, Sharp recommends installing optional MX-EB17 for maximum performance. *15 Based on Sharp's standard chart with approx. 700 characters (A4 portrait) at standard resolution in Super G3 mode, 33,600 bps, JBIG compression.

Design and specifications are subject to change without prior notice. All information was correct at time of print. The ENERGY STAR logo is a certification mark and may only be used to certify specific products that have been determined to meet the ENERGY STAR programme requirements. ENERGY STAR is a US registered mark. Windows, Windows NT and Windows Vista are registered trademarks of Microsoft Corporation. PostScript 3 is either registered trademarks or trademarks of Adobe Systems Incorporated in the U.S. and/or other countries. All other company names, product names and logo types are trademarks or registered trademarks of their respective owners. ©Sharp Corporation February 2015. Ref: Brochure DX-2500N. Job No: 15941. All trademarks acknowledged. E80E.

